

# DGHDP STANDARD COMPONENTS

Room Layout Sheet

Room Name **Store - Photocopy/Stationery**

ID No **STPS**

- AS ADJUSTABLE SHELF
- COM/2 COMMUNICATION OUTLET- DOUBLE
- GPO/2 GENERAL PURPOSE OUTLET-DOUBLE
- LS LIGHT SWITCH
- SK5 FEATHER EDGE VINYL SKIRTING

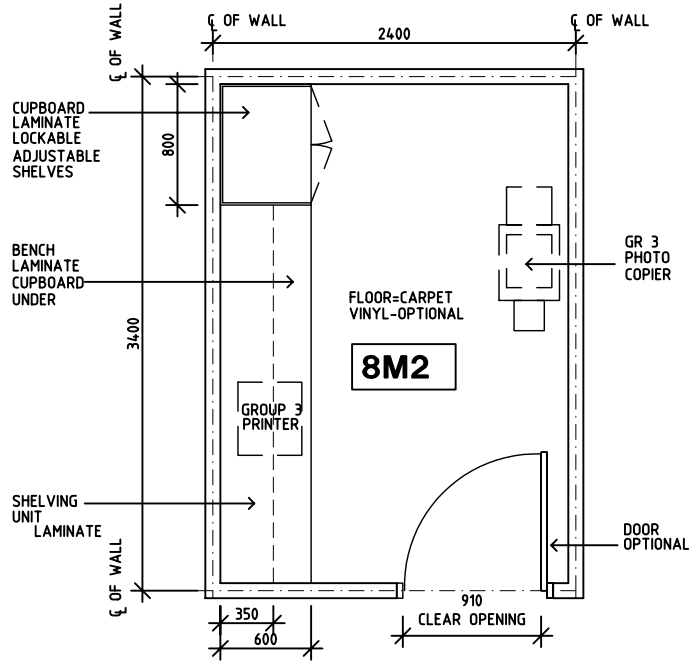

**PLAN**

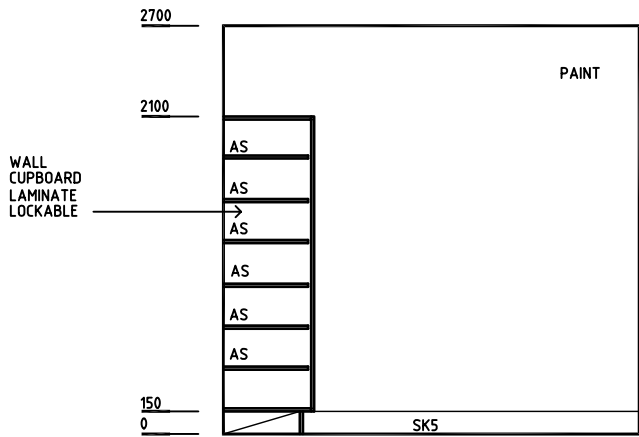

**ELEVATION 1**

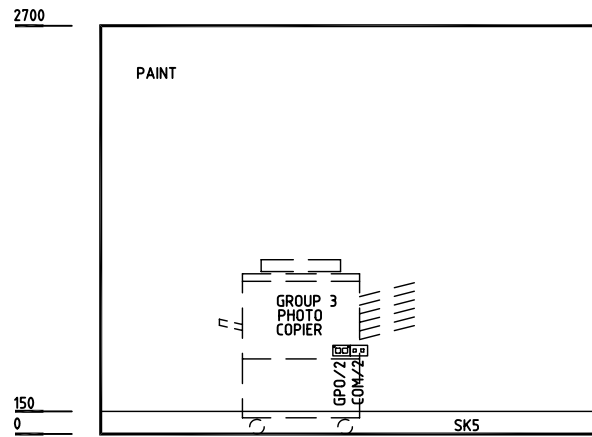

**ELEVATION 2**

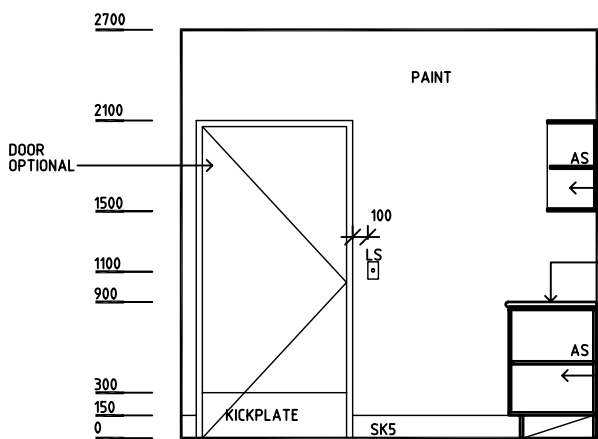

**ELEVATION 3**

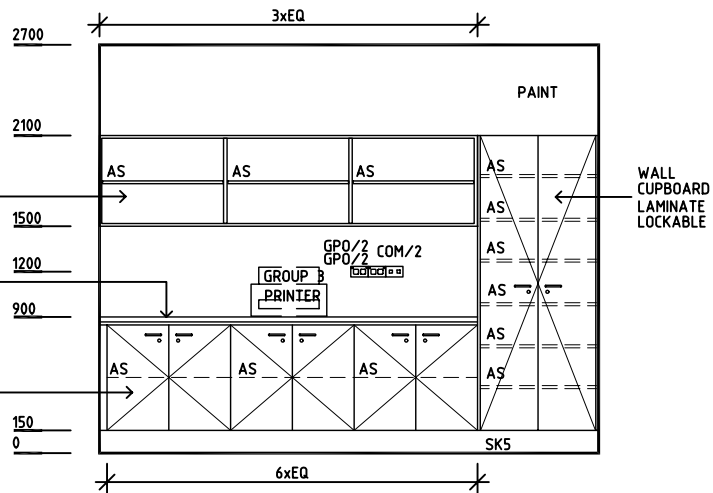

**ELEVATION 4**

Rev	Revision Description	Date	Rev	Revision Description	Date	Rev	Revision Description	Date
1	FIRST ISSUE	27.9.04						
2	DRAWING REVISED	22.10.04						