

# DGHDP STANDARD COMPONENTS

Room Layout Sheet

Room Name **Clean Utility - Sub**

ID No **CLUR-S**

- AS ADJUSTABLE SHELF
- COM/2 COMMUNICATION OUTLET-DOUBLE
- DDG DISPENSER - DISPOSABLE GLOVES
- DHT DISPENSER - HAND TOWEL
- DS DISPENSER - SOAP
- DSA DISPENSER - SOAP ANTISEPTIC
- DHM DISPENSER - HAND MOISTURISER
- DP DOOR AND FRAME PROTECTION
- FS FIXED SHELF
- GPO/2 GENERAL PURPOSE OUTLET-DOUBLE
- LS LIGHT SWITCH
- OP OBSERVATION PANEL
- SK4 FLOOR VINYL COVERED SKIRTING
- SS STAINLESS STEEL
- V1 VINYL FLOORING, STANDARD
- WVD WALL VINYL DADO

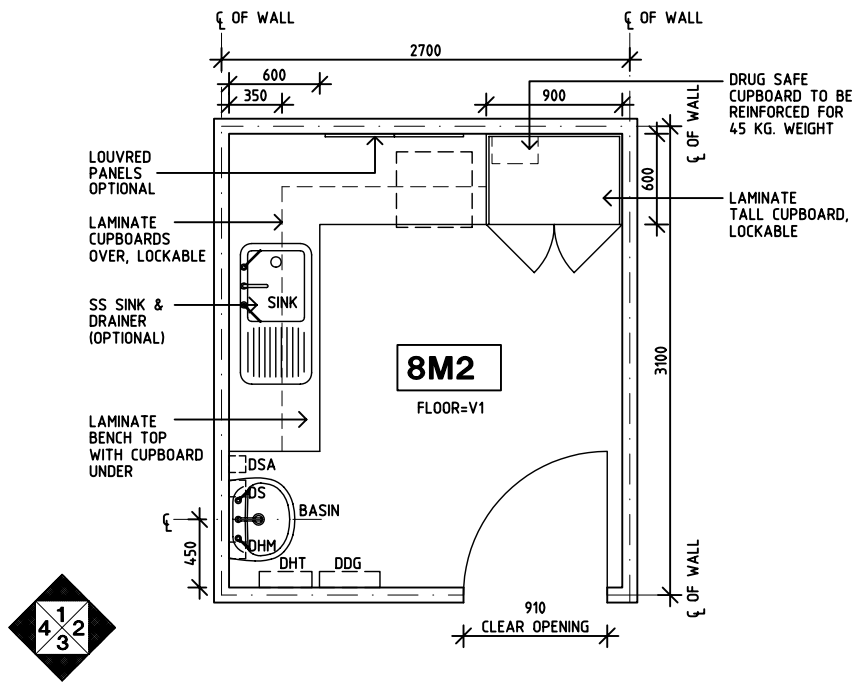

**PLAN**

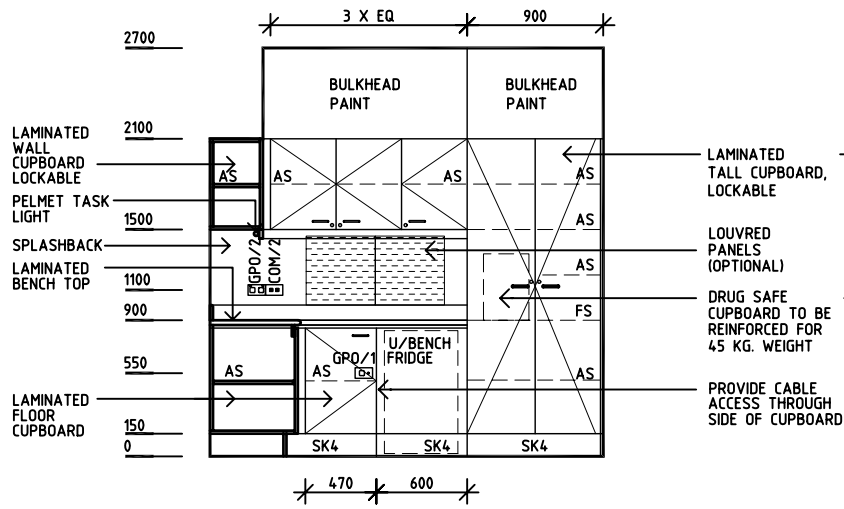

**ELEVATION 1**

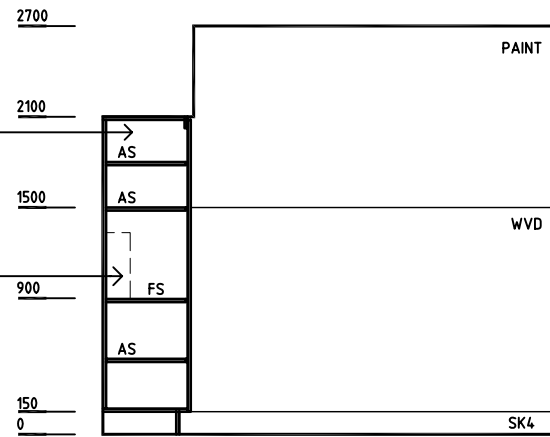

**ELEVATION 2**

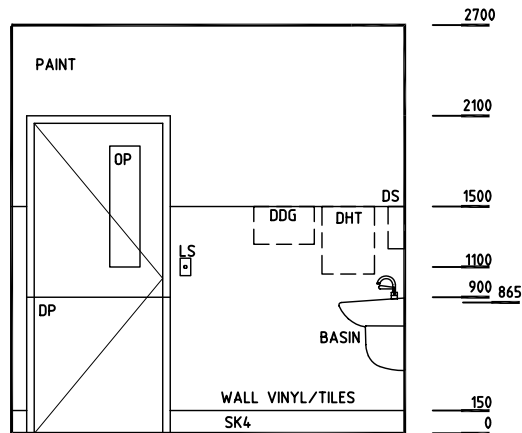

**ELEVATION 3**

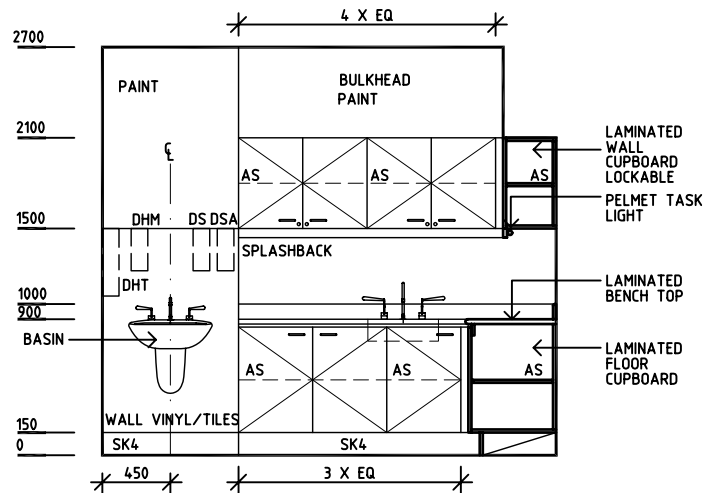

**ELEVATION 4**

Rev	Revision Description	Date	Rev	Revision Description	Date	Rev	Revision Description	Date
1	FIRST ISSUE	22.10.04						