

# SHARJAH HEALTHCARE CITY STANDARD COMPONENTS

Room Layout Sheet

Room Name **Store - Patient Property**

RLS Room Code **STPP-SJ**

RDS Room Code **STPP-SJ**

- DP DOOR AND DOOR FRAME PROTECTION
- GPO/2 GENERAL POWER OUTLET-DOUBLE
- LS/R LIGHT SWITCH - ROOM
- SK4 FLOOR VINYL COVERED SKIRTING
- V1 VINYL FLOORING STANDARD ALIP RESISTANT

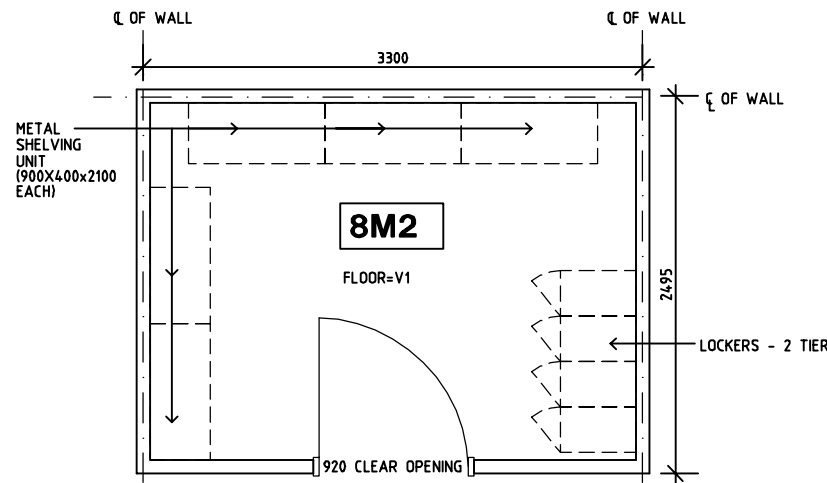

**PLAN**

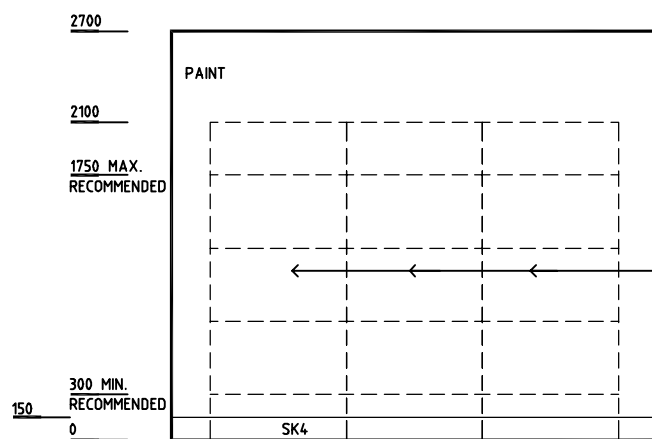

**ELEVATION 1**

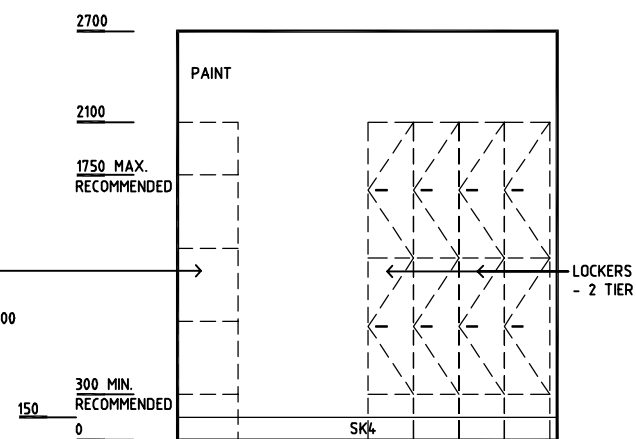

**ELEVATION 2**

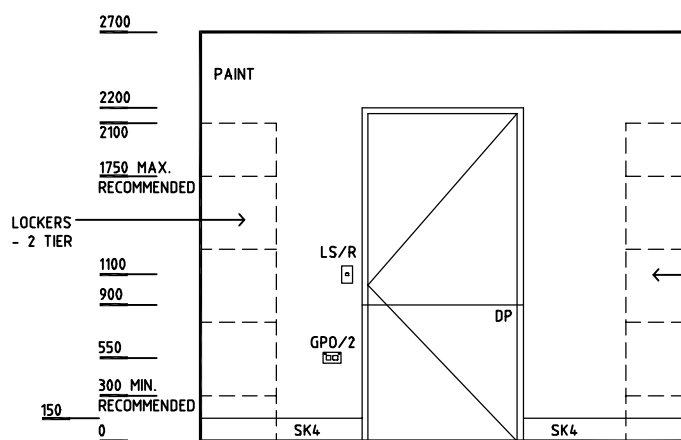

**ELEVATION 3**

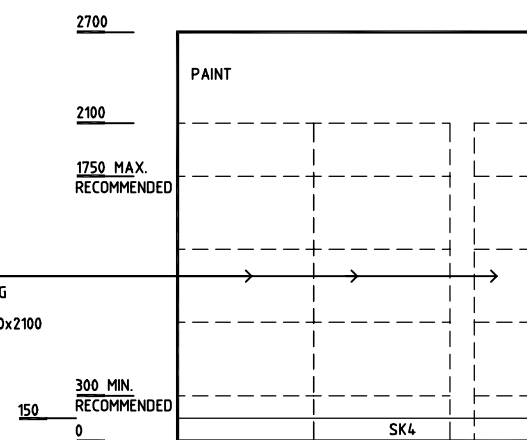

**ELEVATION 4**

REV	DESCRIPTION	DATE	BY	REV	DESCRIPTION	DATE	BY	REV	DESCRIPTION	DATE	BY
1	FIRST ISSUE	14.03.2014	AA								

	<b>SHCC Guidelines</b>	Sharjah Health Facility Guidelines at: <a href="http://www.healthdesign.com.au/shcc/hfg">www.healthdesign.com.au/shcc/hfg</a> Editable version of Standard Components on Health Facility Briefing System (HFBS) at: <a href="http://www.healthdesign.com.au">www.healthdesign.com.au</a> Provided by TAHPI	DESIGNED CC	APPROVED DB	DATE 30.12.13	SCALE(S) 1:50 in A3	SHEET 1 of 1
	CAD FILE NAME STPP-SJ		PAPER DRAWING ID STPP-SJ		ISSUE 1		

This document is for advisory purpose only