

SHARJAH HEALTHCARE CITY STANDARD COMPONENTS

Room Layout Sheet

Room Name **Store - Flammable Liquid**

RLS Room Code **STFL-SJ**

RDS Room Code **STFL-SJ**

CONC | CONCRETE TROWEL FINISH

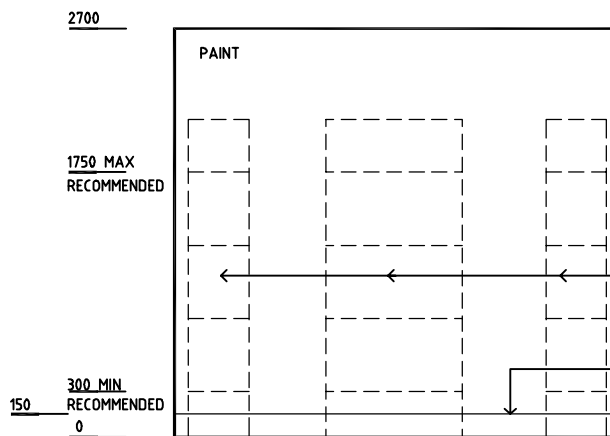
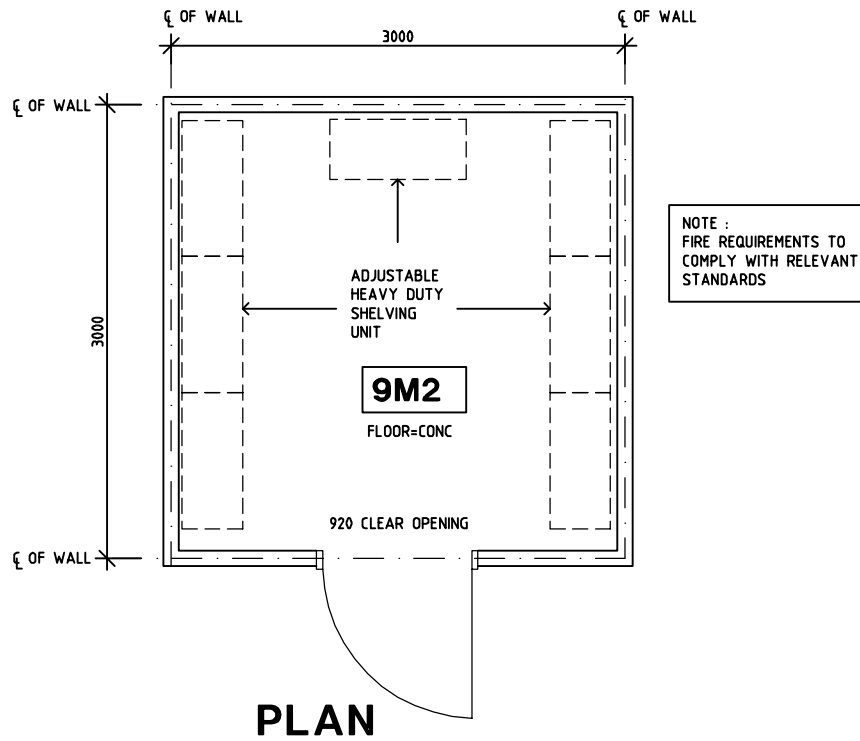

ELEVATION 1

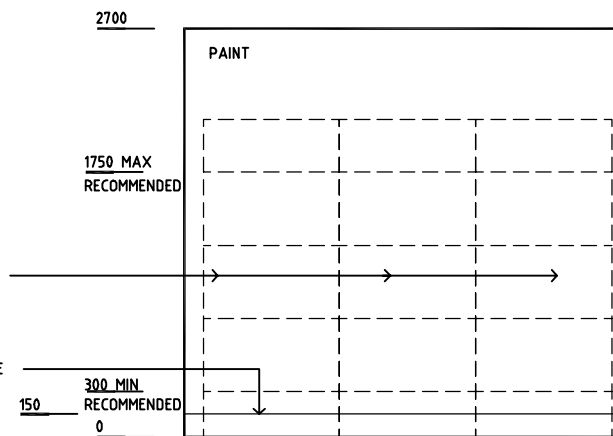

ELEVATION 2

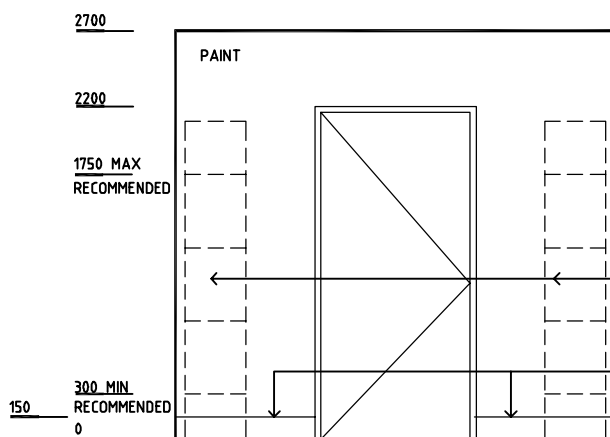

ELEVATION 3

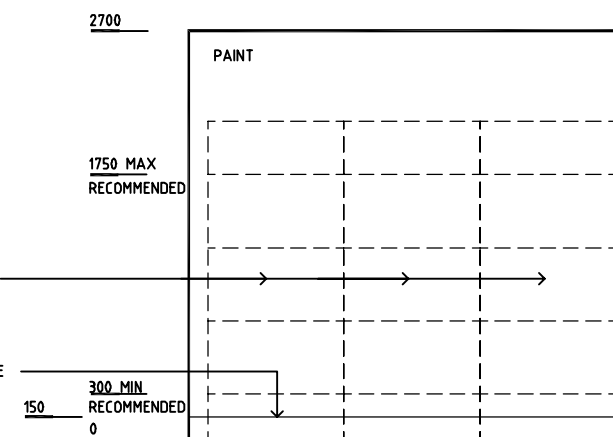

ELEVATION 4

REV	DESCRIPTION	DATE	BY	REV	DESCRIPTION	DATE	BY	REV	DESCRIPTION	DATE	BY
1	FIRST ISSUE	14.03.2014	AA								

	Sharjah Health Facility Guidelines at: www.healthdesign.com.au/shcc/hfg Editable version of Standard Components on Health Facility Briefing System (HFBS) at: www.healthdesign.com.au Provided by TAHPI				DESIGNED	APPROVED	DATE	SCALE(S)	SHEET
	CC	DB	30.12.13	1:50 in A3	1 of 1				
	CAD FILE NAME		PAPER DRAWING ID		ISSUE				
STFL-SJ		STFL-SJ		1					

This document is for advisory purpose only