

# SHARJAH HEALTHCARE CITY STANDARD COMPONENTS

Room Layout Sheet

Room Name **Pantry - Super VIP**

RLS Room Code

**PTRY-SVIP-SJ**

RDS Room Code

**PTRY-SVIP-SJ**

- AS ADJUSTABLE SHELF
- BWU BOILING WATER UNIT
- DHT DISPENSER - HAND TOWEL
- DS DISPENSER - SOAP
- FS FIXED SHELF
- GPO/1 GENERAL POWER OUTLET - SINGLE
- GPO/2 GENERAL POWER OUTLET - DOUBLE
- LS/R LIGHT SWITCH/ROOM
- OP OBSERVATION PANEL

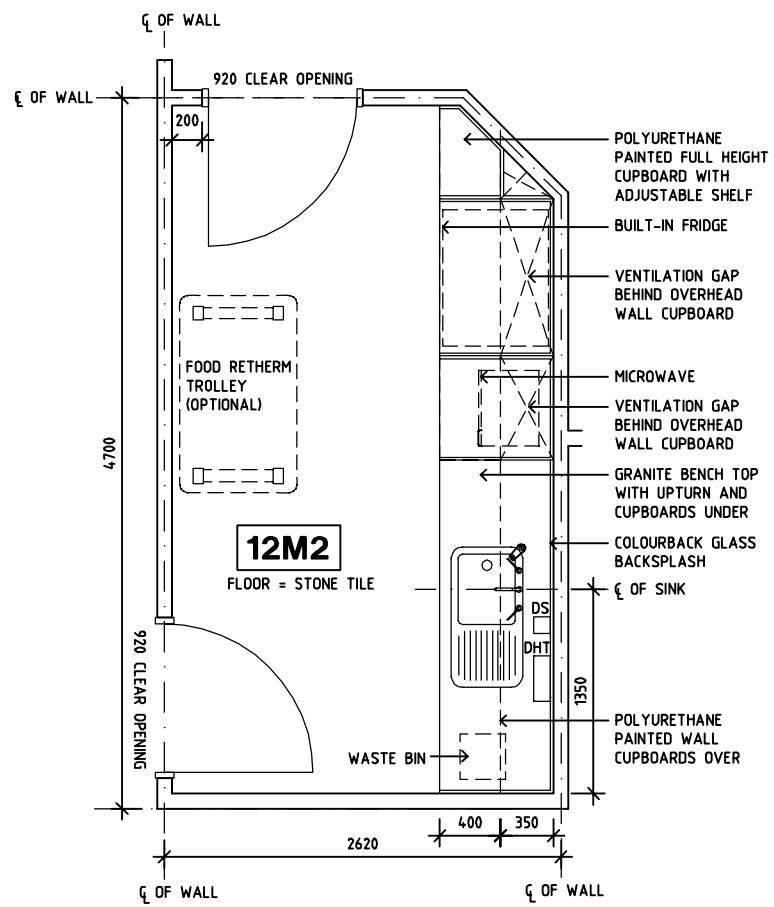

**PLAN**

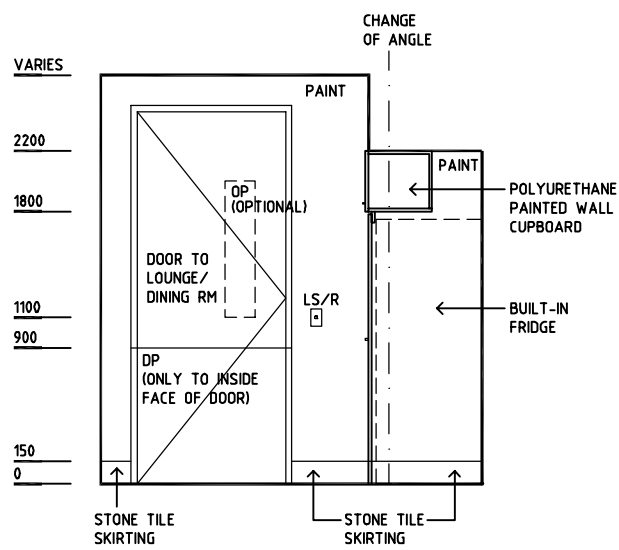

**ELEVATION 1**

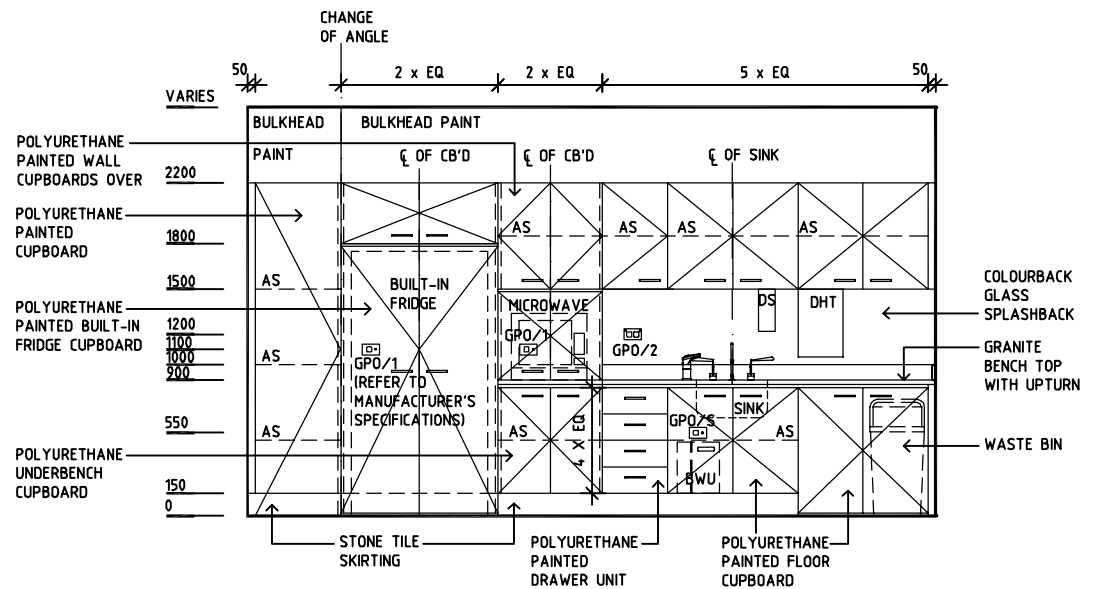

**ELEVATION 2**

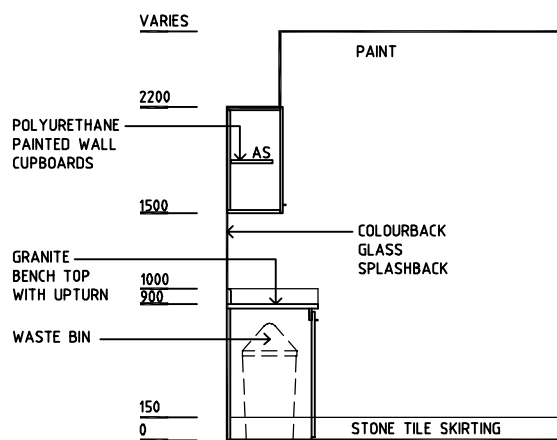

**ELEVATION 3**

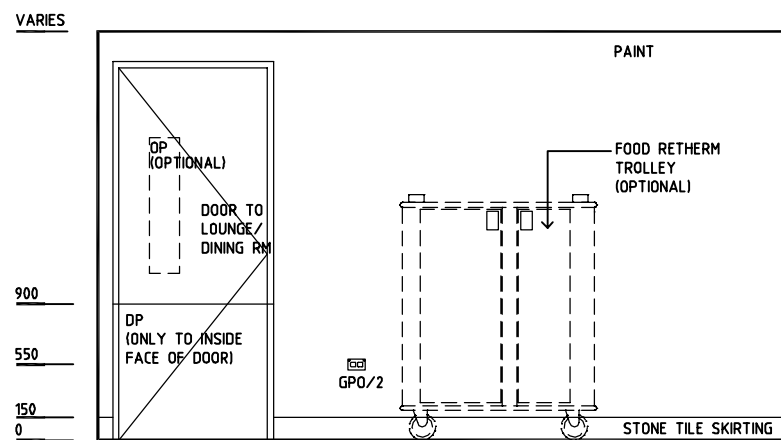

**ELEVATION 4**

REV	DESCRIPTION	DATE	BY	REV	DESCRIPTION	DATE	BY	REV	DESCRIPTION	DATE	BY
1	FIRST ISSUE	14.03.2014	AA								



Sharjah Health Facility Guidelines at:  
[www.healthdesign.com.au/shcc/hfg](http://www.healthdesign.com.au/shcc/hfg)  
 Editable version of Standard Components on  
 Health Facility Briefing System (HFBS) at:  
[www.healthdesign.com.au](http://www.healthdesign.com.au)  
 Provided by TAHPI

DESIGNED	APPROVED	DATE	SCALE(S)	SHEET
CC	DB	30.12.13	1:50 in A3	1 of 1
CAD FILE NAME		PAPER DRAWING ID		ISSUE
PTRY-SVIP-SJ		PTRY-SVIP-SJ		1

This document is for advisory purpose only