

SHARJAH HEALTHCARE CITY STANDARD COMPONENTS

Room Layout Sheet

Room Name **Lounge - Parent, 12m2**

RLS Room Code **LNPA-12-SJ**
RDS Room Code **LNPA-12-SJ**

- COM/2 COMMUNICATION OUTLET - DOUBLE
- DP DOOR AND DOOR FRAME PROTECTION
- GL GLAZING
- GPO/1 GENERAL POWER OUTLET - SINGLE
- LS/R LIGHT SWITCH - ROOM
- MATV MASTER ANTENNA TV CONNECTION
- SK7 TIMBER SKIRTING
- V1 VINYL FLOORING, STANDARD SLIP RESISTANT

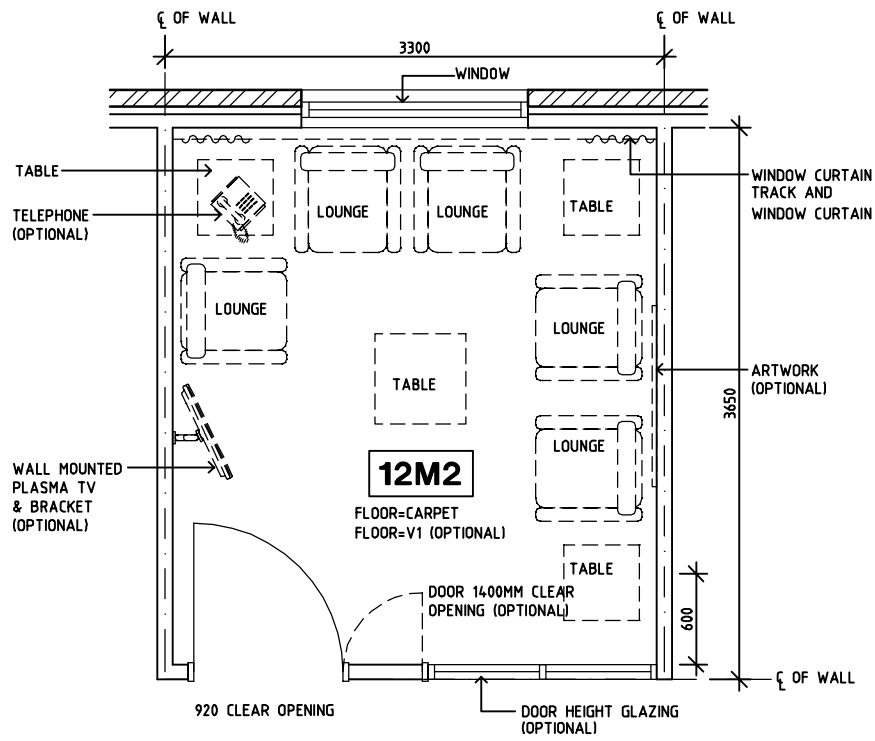

PLAN

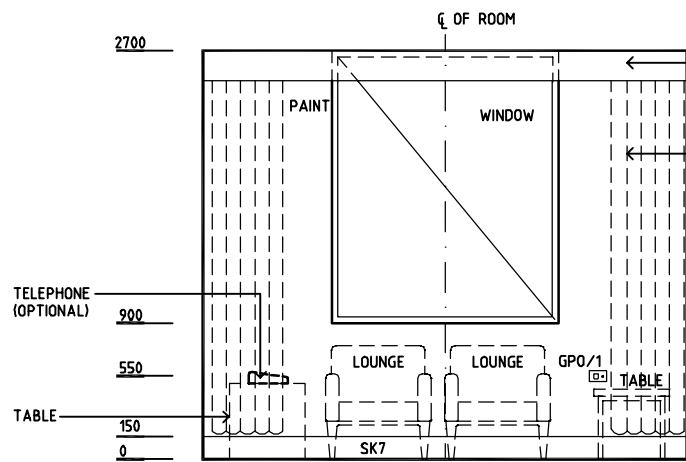

ELEVATION 1

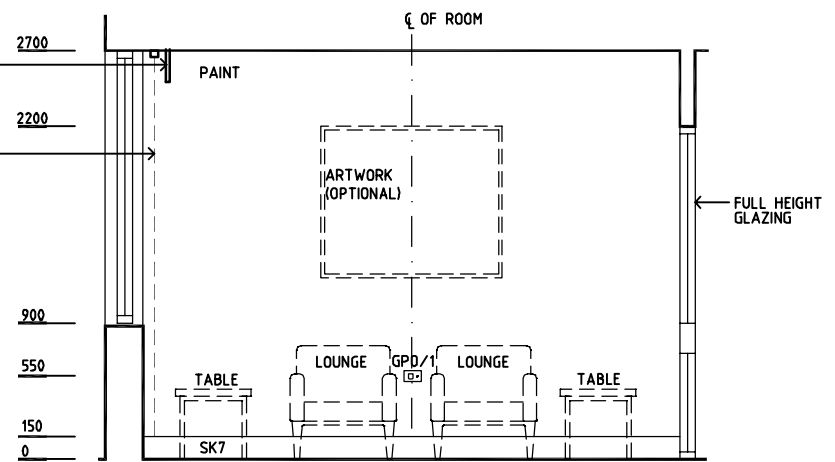

ELEVATION 2

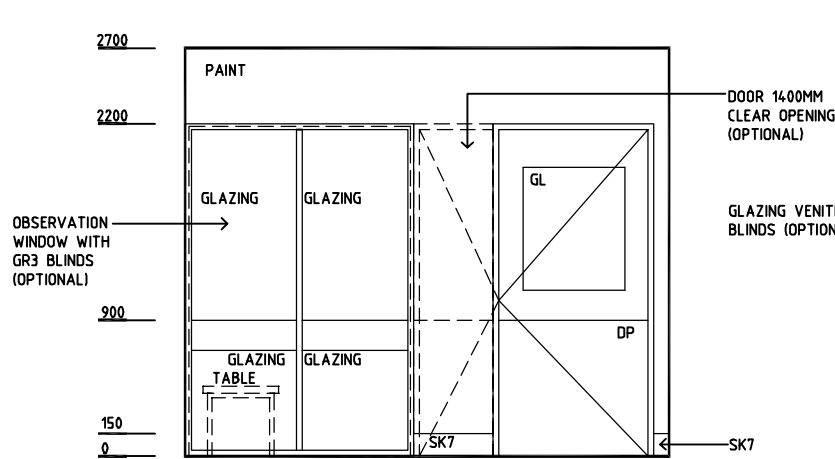

ELEVATION 3

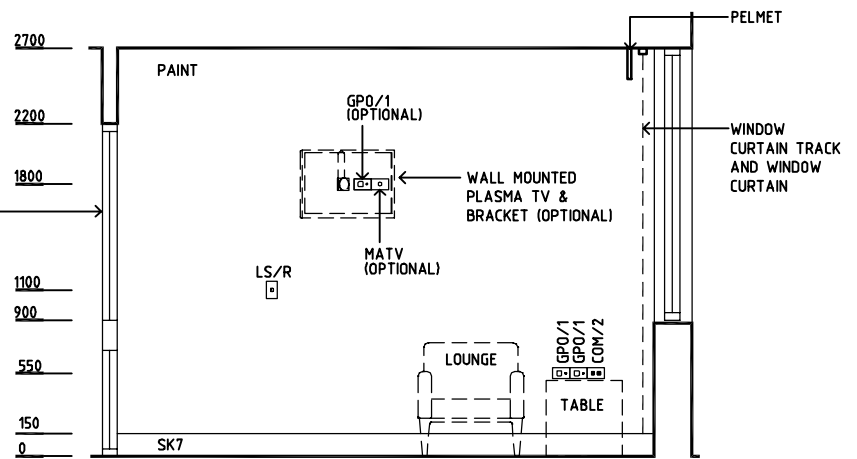

ELEVATION 4

REV	DESCRIPTION	DATE	BY	REV	DESCRIPTION	DATE	BY	REV	DESCRIPTION	DATE	BY
1	FIRST ISSUE	14.03.2014	AA								



Sharjah Health Facility Guidelines at:
www.healthdesign.com.au/shcc/hfg
Editable version of Standard Components on
Health Facility Briefing System (HFBS) at:
www.healthdesign.com.au
Provided by TAHPI

DESIGNED	APPROVED	DATE	SCALE(S)	SHEET
CC	DB	30.12.13	1:50 in A3	1 of 1
CAD FILE NAME		PAPER DRAWING ID		ISSUE
LNPA-12-SJ		LNPA-12-SJ		1

This document is for advisory purpose only