

# SHARJAH HEALTHCARE CITY STANDARD COMPONENTS

Room Layout Sheet

Room Name **Laundry - Patient**

RLS Room Code **LAUN-PT-SJ**

RDS Room Code **LAUN-PT-SJ**

- AS ADJUSTABLE SHELF
- CW COLD WATER
- DP DOOR AND DOOR FRAME PROTECTION
- FW FLOOR WASTE
- GP0/1 GENERAL POWER OUTLET - SINGLE
- GP0/2 GENERAL POWER OUTLET - DOUBLE
- HW HOT WATER
- LS/R LIGHT SWITCH-ROOM
- OP OBSERVATION PANEL
- SK4 FLOOR VINYL COVERED SKIRTING
- SS STAINLESS STEEL
- V4 VINYL FLOORING, NONSLIP- SAFETY

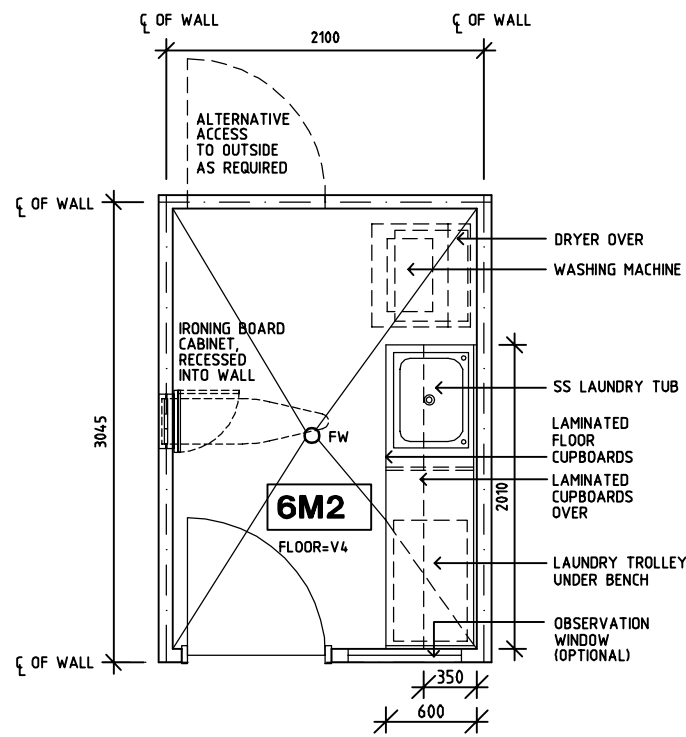

**PLAN**

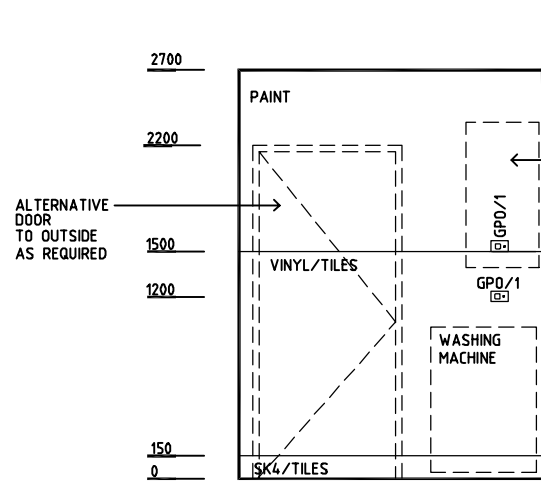

**ELEVATION 1**

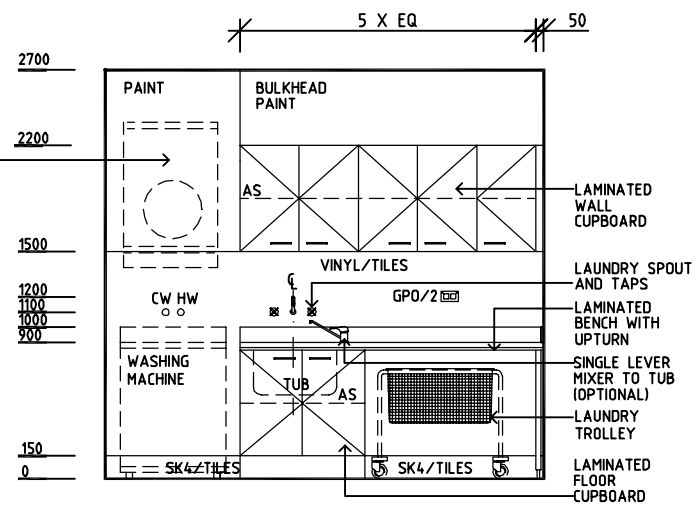

**ELEVATION 2**

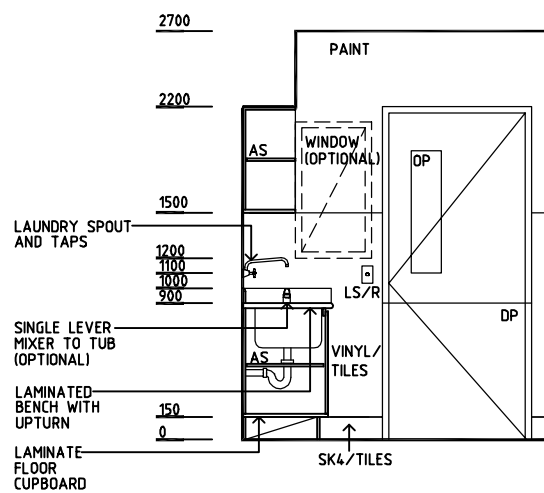

**ELEVATION 3**

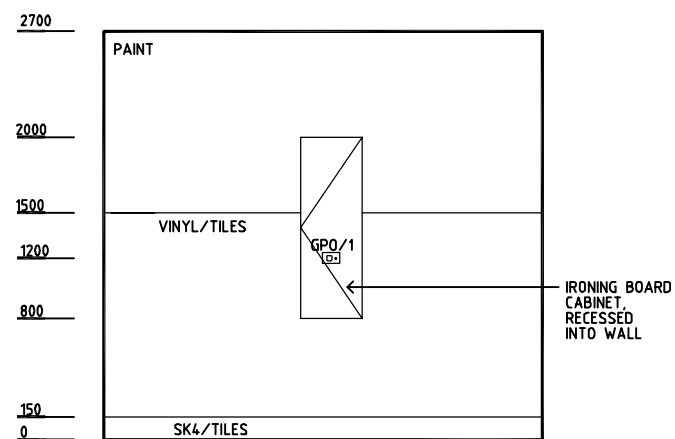

**ELEVATION 4**

REV	DESCRIPTION	DATE	BY	REV	DESCRIPTION	DATE	BY	REV	DESCRIPTION	DATE	BY
1	FIRST ISSUE	14.03.2014	AA								



Sharjah Health Facility Guidelines at:  
[www.healthdesign.com.au/shcc/hfg](http://www.healthdesign.com.au/shcc/hfg)  
 Editable version of Standard Components on  
 Health Facility Briefing System (HFBS) at:  
[www.healthdesign.com.au](http://www.healthdesign.com.au)  
 Provided by TAHPI

DESIGNED	APPROVED	DATE	SCALE(S)	SHEET
CC	DB	30.12.13	1:50 in A3	1 of 1
CAD FILE NAME		PAPER DRAWING ID		ISSUE
LAUN-PT-SJ		LAUN-PT-SJ		1