

# NSW HFG STANDARD COMPONENTS

Room Layout Sheet

Room Name **Patient Bay - Critical (Enclosed), 25m2**

RLS Room Code **PBCE-25**

RDS Room Code **PBCE-25**

- COM/2 COMMUNICATION OUTLET - DOUBLE
- DDG DISPENSER - DISPOSABLE GLOVES
- DGL DOUBLE GLAZING
- DHT DISPENSER - HAND TOWEL
- DSA DISPENSER - SOAP ANTISEPTIC
- DS DISPENSER - SOAP
- GPO/1 GENERAL PURPOSE OUTLET - SINGLE
- GPO/1 EP EMERGENCY POWER - SINGLE
- GPO/2 EP EMERGENCY POWER - DOUBLE
- GPO/2 GENERAL PURPOSE OUTLET - DOUBLE
- GPO/C GENERAL PURPOSE OUTLET - CLEANER'S
- LS LIGHT SWITCH
- RCD RESIDUAL CURRENT DEVICE
- RO REVERSE OSMOSIS
- SK4 FLOOR VINYL COVERED SKIRTING
- V1 VINYL FLOORING STANDARD
- UPS UNINTERRUPTABLE POWER SUPPLY
- WB WHITEBOARD
- WT WALL TELEPHONE

- SERVICE PENDANTS :
- 1 x EMERGENCY CALL
  - 1 x NURSE ASSIST CALL
  - 1 x PATIENT/NURSE CALL & HANDSET
  - 12 x GPO/1
  - 12 x GPO/1 EP (2 ON UPS)
  - 4 x OXYGEN
  - 2 x MEDICAL AIR
  - 4 x SUCTION
  - 1 x MONITOR CONNECTION
  - 1 x DATA POINT, DOUBLE
  - 1 x RCD

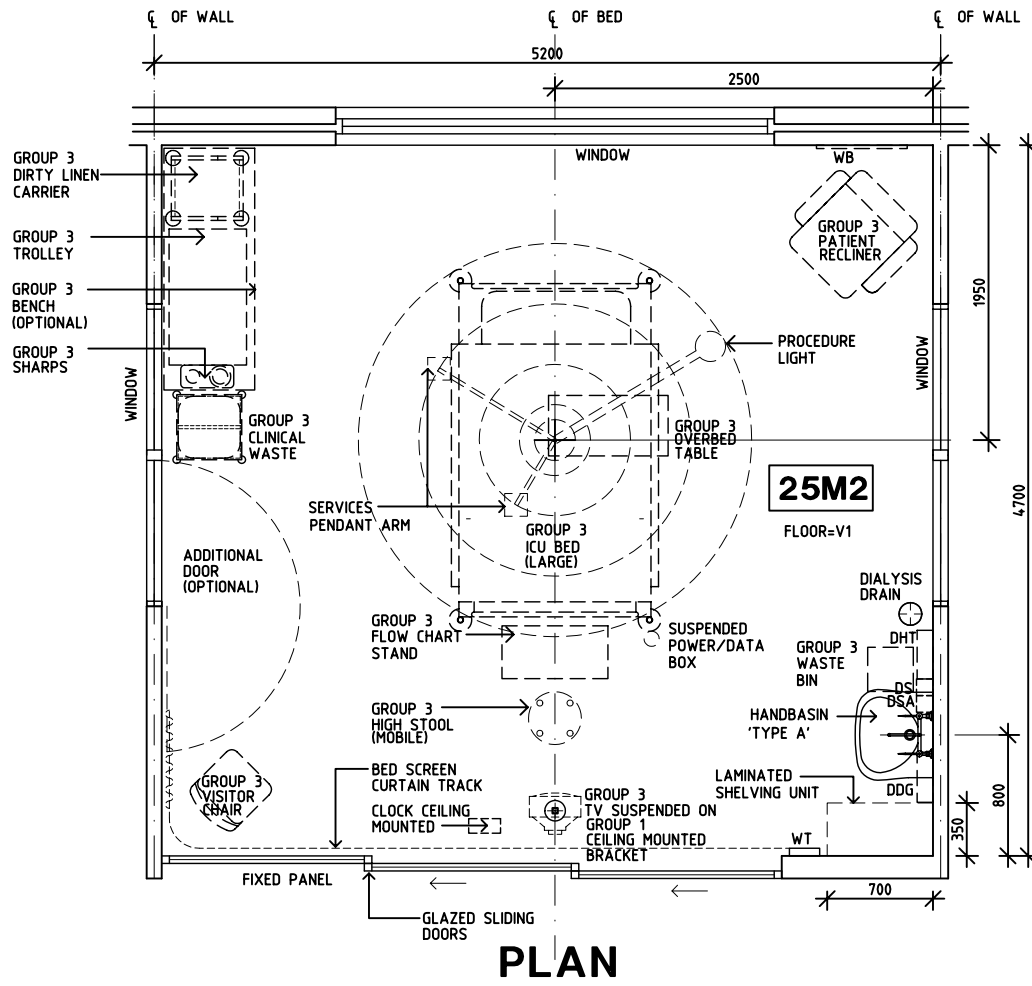

NOTE:  
LARGE BED SHOWN  
TO INDICATE CAPACITY  
OF ROOM TO  
ACCOMMODATE IT.

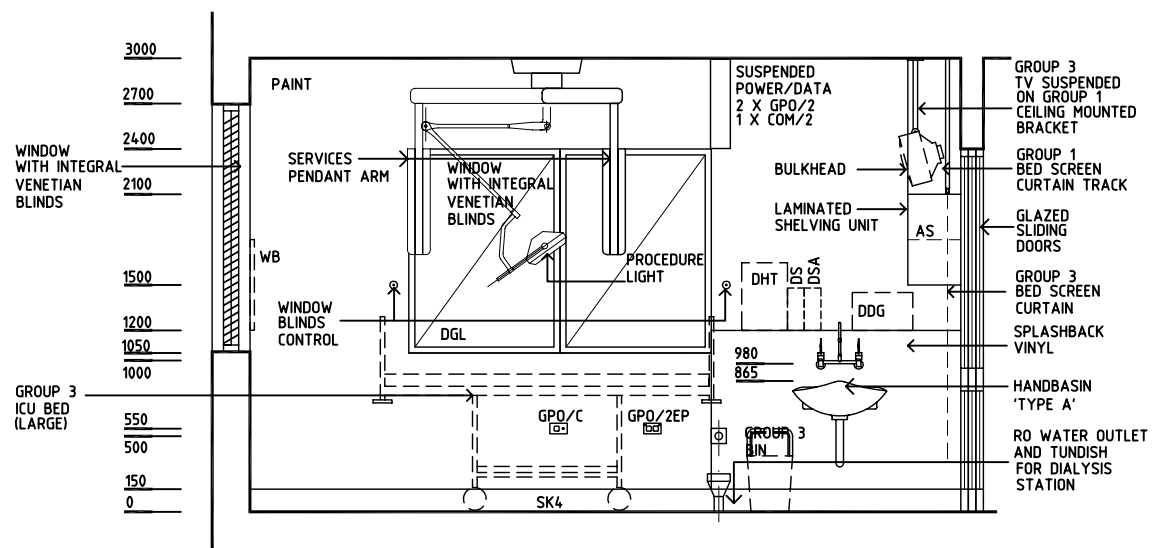
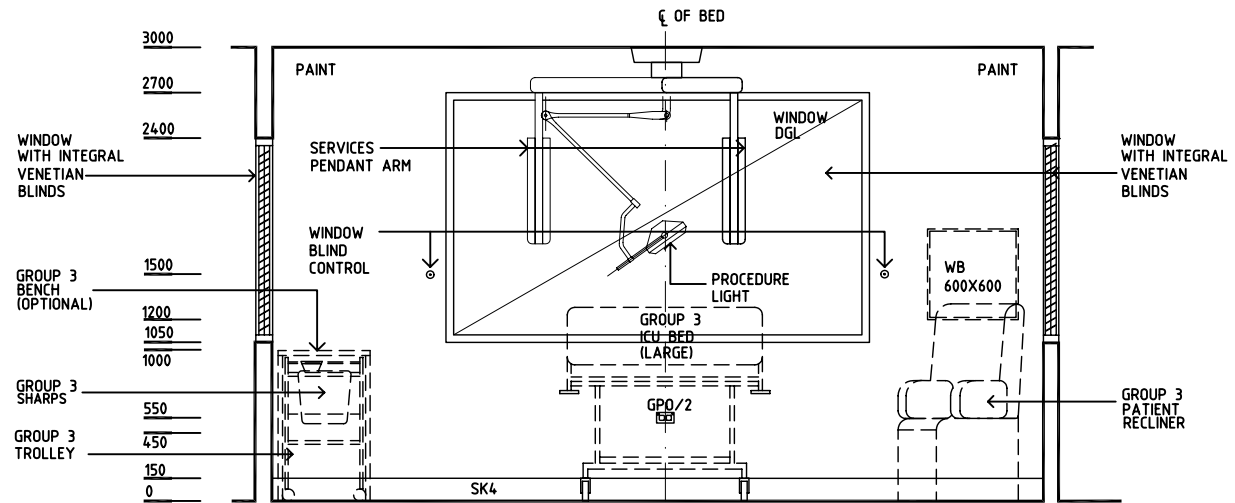

REV	DESCRIPTION	DATE	BY	REV	DESCRIPTION	DATE	BY	REV	DESCRIPTION	DATE	BY
1	FIRST ISSUE	21.11.03	JT								
2	GENERAL REVISIONS INCL NAME CHANGE	31.5.05	AL								



THE UNIVERSITY OF  
NEW SOUTH WALES

HPI

DESIGNED	APPROVED	SCALE(S)	ZONE(S)
JT/AL	DB	1:50 in A3	
CAD FILE NAME PBCE-25		PAPER DRAWING ID PBCE-25a	

# NSW HFG STANDARD COMPONENTS

Room Layout Sheet

Room Name **Patient Bay - Critical (Enclosed), 25m2**

RLS Room Code **PBCE-25**

RDS Room Code **PBCE-25**

- COM/2 COMMUNICATION OUTLET - DOUBLE
- DDG DISPENSER - DISPOSABLE GLOVES
- DGL DOUBLE GLAZING
- DHT DISPENSER - HAND TOWEL
- DSA DISPENSER - SOAP ANTISEPTIC
- DS DISPENSER - SOAP
- GPO/1 GENERAL PURPOSE OUTLET - SINGLE
- GPO/1 EP EMERGENCY POWER - SINGLE
- GPO/2 EP EMERGENCY POWER - DOUBLE
- GPO/2 GENERAL PURPOSE OUTLET - DOUBLE
- GPO/C GENERAL PURPOSE OUTLET - CLEANER'S
- LS LIGHT SWITCH
- RCD RESIDUAL CURRENT DEVICE
- RO REVERSE OSMOSIS
- SK4 FLOOR VINYL COVERED SKIRTING
- V1 VINYL FLOORING STANDARD
- UPS UNINTERRUPTABLE POWER SUPPLY
- WB WHITEBOARD
- WT WALL TELEPHONE

- SERVICE PENDANTS :
- 1 x EMERGENCY CALL
  - 1 x NURSE ASSIST CALL
  - 1 x PATIENT/NURSE CALL & HANDSET
  - 12 x GPO/1
  - 12 x GPO/1 EP (2 ON UPS)
  - 4 x OXYGEN
  - 2 x MEDICAL AIR
  - 4 x SUCTION
  - 1 x MONITOR CONNECTION
  - 1 x DATA POINT, DOUBLE
  - 1 x RCD

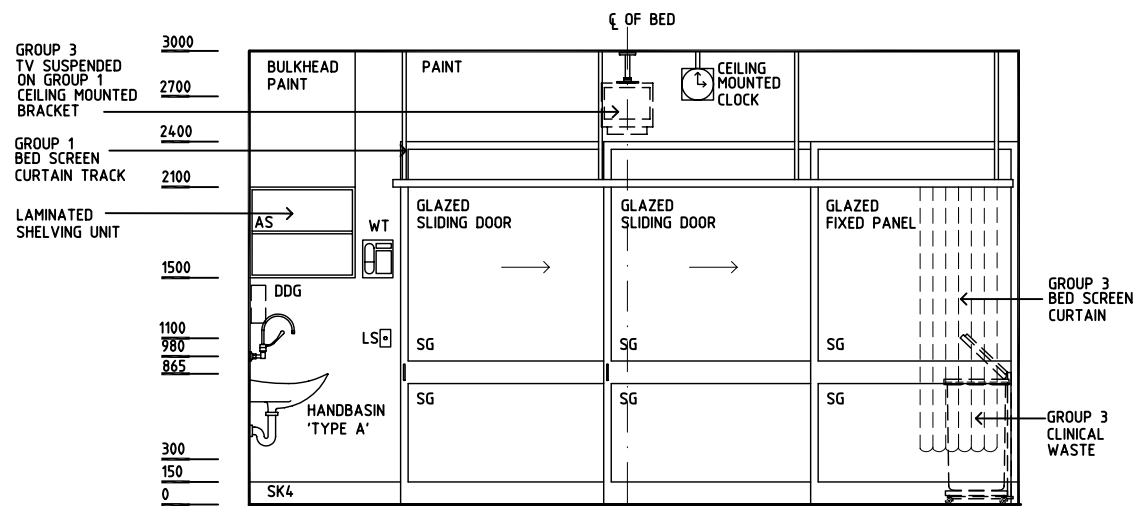

**ELEVATION 3**

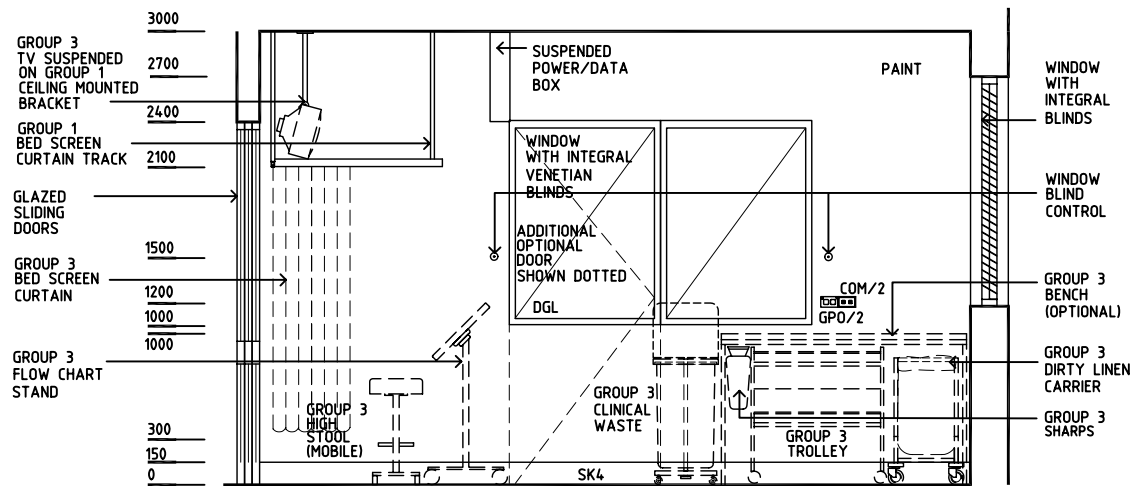

**ELEVATION 4**

REV	DESCRIPTION	DATE	BY	REV	DESCRIPTION	DATE	BY	REV	DESCRIPTION	DATE	BY
1	FIRST ISSUE	21.11.03	JT								
2	GENERAL REVISIONS INCL NAME CHANGE	31.5.05	AL								



THE UNIVERSITY OF  
NEW SOUTH WALES

HPI

DESIGNED	APPROVED	SCALE(S)	ZONE(S)
JT/AL	DB	1:50 in A3	
CAD FILE NAME PBCE-25		PAPER DRAWING ID PBCE-25b	